

Electronic Timing Relays Class 9050 Type JCK

Retain for future use.

Introduction

This bulletin contains installation and operation instructions for the following Class 9050 electronic timing relays:

- Type JCK11–59
- Type JCK60
- Type JCK70

⚠ DANGER

HAZARD OF ELECTRIC SHOCK, EXPLOSION, OR ARC FLASH

Turn off all power supplying this equipment before working on it.

Failure to follow these instructions will result in death or serious injury.

Timing Functions

The 9050JCK¹ is an electronic time delay relay. A microprocessor clocks the elapsed time, executes the timing functions, and controls the output relay. Table 1 describes the ten timing functions.

NOTE: All functions may not be available for all JCK timers.

Table 1: 9050JCK[•] Electronic Timing Functions

Function	Applies To		Description	Timing Diagram
On Delay	Adjustable Time Delay	Fixed Time Delay	When the input voltage is applied, the time delay begins. Relay contacts change state after time delay is complete. When the input voltage is removed, contacts return to their shelf state. The trigger switch is not used in this function.	
	JCK1–19	JCK1F [•]		
	Single Function Timer			
	JCK60			
	Multifunction Timer			
JCK70				
Interval	Adjustable Time Delay	Fixed Time Delay	When the input voltage is applied, the relay contacts change state immediately and the timing cycle begins. When the time delay is complete, or when the input voltage is removed, contacts return to shelf state. The trigger switch is not used in this function.	
	JCK31–39	JCK3F [•]		
	Multifunction Timer			
JCK70				

¹ The "•" indicates that the part number applies to all timing relays specified in this instruction bulletin.

Table 1: 9050JCK• Electronic Timing Functions (continued)

Function	Applies To		Description	Timing Diagram
Off Delay Switch and Power Trigger	Switch Trigger		Input voltage must be applied continuously. When the trigger switch closes, the relay contacts change state. When the trigger switch opens, the time delay begins. When the delay is complete, the contacts return to their shelf state. If the trigger switch closes before the time delay is complete, then timing is reset. When the trigger switch opens, the delay begins again, and the relay contacts remain in their energized state. If the input voltage is removed, the relay contacts return to their shelf state.	
	Adjustable Time Delay	Fixed Time Delay		
	JCK21-29	JCK2F•		
	Power Trigger			
	Adjustable Time Delay	Fixed Time Delay		
	JCK21PT-29PT	JCK2F•PT		
Multifunction Timers		JCK70		
One Shot Switch and Power Trigger	Switch Trigger		Input voltage must be applied continuously. When the trigger switch closes, the relay contacts change state and the pre-set delay begins. During time-out, the trigger signal is ignored. If the input voltage is removed, the relay contacts return to their shelf state.	
	Adjustable Time Delay	Fixed Time Delay		
	JCK41-49	JCK4F•PT		
	Power Trigger			
	Adjustable Time Delay	Fixed Time Delay		
	JCK41PT-49PT	JCK4F•PT		
Multifunction Timer		JCK70		
Repeat Cycle-Off	Adjustable Time Delay	Fixed Time Delay	When input voltage is applied, the time delay T1 begins. When time delay T1 is complete, the relay contacts change state for time delay T2. This cycle repeats until the input voltage is removed. The trigger switch is not used in his function. NOTE: Two dials are provided for independently adjustable repeat cycle timing ranges. For JCK70 timing relay, T1 equals T2.	
	JCK51-59	JCK5F•		
	Multifunction Timer			
Repeat Cycle-On	Multifunction Timer		When input voltage is applied, the relay contacts change state immediately and time delay T1 begins. When time delay T1 is complete, the contacts return to their shelf state for time delay T1. This cycle repeats until the input voltage is removed. The trigger switch is not used in this function.	
	JCK70			
On/Off Delay	Multifunction Timer		Upon application of input voltage, the time delay relay is ready to accept trigger signals. When the trigger switch closes, a pre-set On delay begins. At the end of the On delay, the relay contacts change state. When the trigger switch opens, the relay contacts remain in the current state until the pre-set Off delay elapses. At the end of the Off delay, the relay contacts return to their shelf state. The cycle can be repeated by re-closing the trigger switch after the timing cycle ends. If the trigger switch opens before the On delay elapses, the relay remains in its shelf state, and the delay timer resets. If the trigger switch re-closes before the Off delay elapses, the relay remains in its changed state, and the delay timer resets.	
	JCK70			

Table 1: 9050JCK• Electronic Timing Functions (continued)

Function	Applies To	Description	Timing Diagram
One Shot Falling Edge	Multifunction Timer	Upon application of input voltage, the time delay relay is ready to accept trigger signals. When the trigger switch closes, the relay remains in its shelf state. When the trigger switch opens, the relay contacts change state and a pre-set time delay begins. At the end of the time delay, the relay contacts return to their shelf state unless the trigger switch closes and opens before the time delay elapses. Continuous cycling of the trigger signal at a rate faster than the time delay causes the relay to remain in its changed state.	
	JCK70		
Watchdog	Multifunction Timer	Upon application of input voltage, the time delay relay is ready to accept trigger signals. When the trigger switch closes, the relay contacts change state and the pre-set time delay begins. At the end of the time delay, the relay contacts return to their shelf state unless the trigger switch closes and opens before the time delay elapses. Continuous cycling of the trigger signal at a rate faster than the delay time causes the relay to remain in its changed state.	
	JCK70		
Trigger On Delay	Multifunction Timer	Upon application of input voltage, the time delay relay is ready to accept trigger signals. When the trigger switch closes, a pre-set time delay begins. At the end of the pre-set time delay, the relay contacts change state and remain in that position as long as either the trigger signal is maintained or the input voltage remains. If the trigger switch opens during the time delay, the relay contacts return to their shelf state.	
	JCK70		

Programmable Timing Ranges for Type JCK60 and JCK70 Relays

Table 2: Application Data

JCK60 and JCK70 Timing Ranges	
0.01 s	0.05–9.99 seconds
0.1 s	0.1–99.9 seconds
S	1–999 seconds
0.1 m	0.1–99.9 minutes
M	1–999 minutes
0.1 h	0.1–99.9 hours
H	1–999 hours

JCK60 and JCK70 LED Indicators

Table 3: LED Indicators

LED	State
Steady (On)	Power present
Flashing	Device is timing

NOTE: The LED is not an indicator of the output state of the timing relay.

Wiring Diagrams

NOTE:

1. The timing relays are not compatible with two-wire AC input sensors. A hard contact relay (for instance, a general-purpose relay) must be interposed.
2. Do not apply DC voltage to the 240 Vac timers.
3. Use the same voltage for the power trigger and control power. Do not use terminal 6 with power trigger devices.
4. For timers that use trigger switches, the maximum distance for the trigger switch is 50 ft. from the timer.

Figure 1: JCK11-19; JCK1F•
JCK31- 39; JCK3F•
JCK51-59, JCK5F•, and JCK60

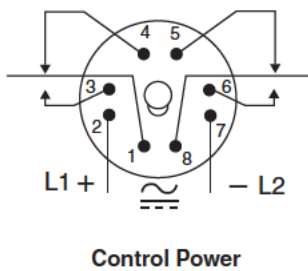

Figure 2: JCK21-29; JCK2F•
JCK41-49; JCK4F•

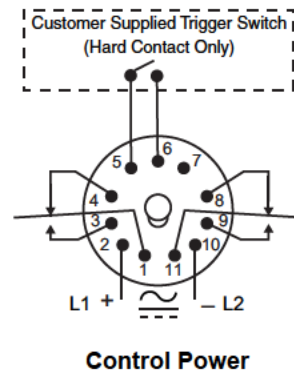

Figure 3: JCK21PT-29PT; JCK2F•PT
JCK41PT-49PT; JCK4F•PT

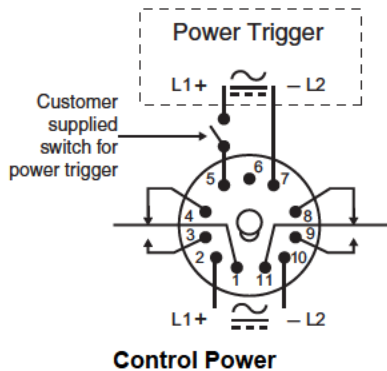
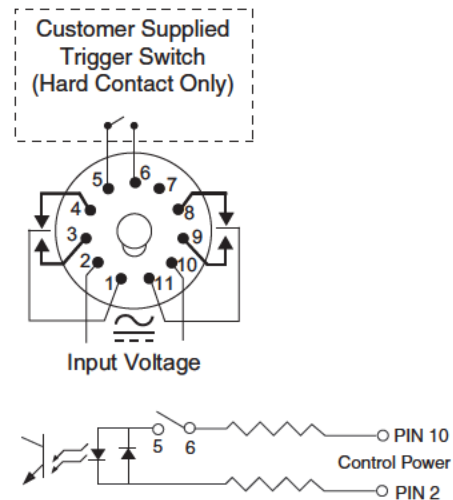

Figure 4: JCK70



Schneider Electric USA, Inc.
8001 Knightdale Blvd
Knightdale, NC 27545
1-888-778-2733
www.schneider-electric.us

Electrical equipment should be installed, operated, serviced, and maintained only by qualified personnel. No responsibility is assumed by Schneider Electric for any consequences arising out of the use of this material.

Square D™ and Schneider Electric™ are trademarks or registered trademarks of Schneider Electric. Other trademarks used herein are the property of their respective owners.